



DSTATCOM Performance for Voltage Sag, Swell Mitigation

Rupali D. Burungale, C. R. Lakade

Student, G. H. Raison Institute of Engineering & Technology, Wagholi, Savitribai Phule Pune University, Pune, India.

Professor, G. H. Raison Institute of Engineering & Technology, Wagholi, Savitribai Phule Pune University,
Pune, India

ABSTRACT: The performance of a DSTATCOM in mitigating voltage sag/ swell is demonstrated with the help of MATLAB. The modeling and simulation results of a DSTATCOM are presented. D-STATCOM is promising device which is used for voltage sag, swell mitigation at distribution side. In this work only the Vrms value is required to measure. DSTATCOM compensator is a flexible device which can operate in current control mode for compensating voltage variation, unbalance and reactive power and in voltage control mode as a voltage stabilizer. The latter feature enables its application for compensation of dips coming from the supplying network. In addition, the regulated VRMS voltage showed a reasonably smooth profile. It was observed that the load voltage is very close to the reference value, i.e., 1pu and the voltage sags are completely minimized. The hardware results showed clearly the performance of the Dstatcom in mitigating voltage sag as well as swell. This thesis explained the two level VSC based DSTATCOM and can be extended to multilevel inverter based DSTATCOM to reduce the harmonic content in current. The DSTATCOM can be designed using a current source inverter. An integrated DSTATCOM controller can be design for voltage regulation, reactive power compensation, power factor improvement and unbalanced load compensation.

KEYWORDS: DSTATCOM, voltage sag, VSI, controller, Swell Mitigation.

I. INTRODUCTION

Power quality determines the fitness of electric power to consumer devices. The term is used to describe electric power that drives an electrical load and load's ability to function properly. Without the proper power, an electrical device may malfunction, fail prematurely or not operate at all. There are many ways in which electric power can be of poor quality and many more causes of such poor quality power. Power quality is certainly a major concern in the present era. It becomes especially important with the insertion of sophisticated devices, whose performance is very sensitive to the quality of power supply. A Power quality problem is an occurrence manifested as a nonstandard voltage, current or frequency that results in a failure or a mis-operation of end user equipment's. Modern industrial processes are mainly based on electronic devices such as PLC's, power electronic devices, drives etc., and since their controls are sensitive to disturbances such as voltage sag, swell and harmonics, voltage sag is most important power quality problems. It contributes more than 80% of power quality (PQ) problems that exist in power systems, and more concern problems faced by many industries and utilities. By definition, voltage sag is an rms (root mean square) reduction in the AC voltage at the power frequency, for duration from a half-cycle to a few seconds. Voltage sag is caused by a fault in the utility system, a fault within the customer's facility or a large increase of the load current, like starting a motor or transformer energizing. Typical faults are single-phase or multiple-phase short circuits, which leads to high currents. The high current results in a voltage drop over the network impedance. Voltage sags are not tolerated by sensitive equipment's used in modern industrial plants such as process controllers, programmable logic controllers (PLC), adjustable speed drive (ASD) and robotics. Various methods have been applied to reduce or mitigate voltage sags. The conventional methods are by using capacitor banks, introduction of new parallel feeders and by installing uninterruptible power supplies (UPS). However, the PQ problems are not solved completely due to uncontrollable reactive power compensation and high costs of new feeders and UPS. The D-STATCOM has emerged as a promising device to provide not only for voltage sags mitigation but a host of other power quality solutions such as voltage stabilization, flicker suppression, power factor correction and harmonic control. One of the most common power quality problems today is voltage dips. A voltage dip is a short time (10 ms to 1 minute) event during which a reduction in



International Journal of Advanced Research in Electrical, Electronics and Instrumentation Engineering

(An ISO 3297: 2007 Certified Organization)

Website: www.ijareeie.com

Vol. 6, Issue 2, February 2017

r.m.s voltage magnitude occurs. It is often set only by two parameters, depth/magnitude and duration. The voltage dip magnitude is ranged from 10% to 90% of nominal voltage (which corresponds to 90% to 10% remaining voltage) and with a duration from half a cycle to 1 min. In a three-phase system a voltage dip is by nature a three-phase phenomenon, which affects both the phase-to-ground and phase-to-phase voltages. A voltage dip is caused by a fault in the utility system, a fault within the customer's facility or a large increase of the load current, like starting a motor or transformer energizing. Typical faults are single-phase or multiple-phase short circuits, which leads to high currents. The high current results in a voltage drop over the network impedance.

II. OBJECTIVES

The main objective of this system is voltage sag mitigation in an unbalanced system.

1. *Study of major source of power quality problems.*
2. *Impact on other equipment and on the power system.*
3. *Measurement techniques*
4. *Mitigation method.*

III. LITERATURE REVIEW

1. MITIGATION OF VOLTAGE SAGS/SWELLS UNBALANCED IN LOW VOLTAGE DISTRIBUTION SYSTEMS

From this Paper we refer-

The main problems of the power quality like voltagesags/swells in low voltage distribution systems and on the transmission side due to sensitive loads, the terminology used for the compensation devices is different. Dynamic Voltage Restorer(DVR) is one of the equipment's for voltage disturbance mitigation in power systems. It is installed between the incoming supply and the sensitive loads to maintain the voltage at the sensitive load from balance. This paper proposes a mitigation of voltage sags/swells in low voltage distribution system using an effective series compensator (DVR). The compensator should protect sensitive loads against of voltage sags/swells. Performance of the proposed method is investigated under different types of fault in both single phase and three phases for various sensitive load conditions. The simulation was carried out with the help of SIMULINK & MATLAB and the results show appropriate operation of the proposed control system.

2. OPTIMAL PLACEMENT OF DSTATCOM FOR VOLTAGE SAG MITIGATION USING AN ANFIS BASED APPROACH FOR POWER QUALITY ENHANCEMENT

From this Paper we refer-

DSTATCOM is one of the equipment's for voltage sag mitigation in power systems. Voltage sag has been considered as one of the most harmful power quality problem as it may significantly affect industrial production. This paper presents an Artificial Neuro fuzzy inference system (ANFIS) based approach for optimal placement of Distribution Static Compensator (DSTATCOM) to mitigate voltage sag under faults. Voltage sag under different type of short circuits has been estimated using MATLAB/SIMULINK software. Optimal location of DSTATCOM has been obtained using a feed forward neural network trained by post-fault voltage magnitude of three phases at different buses. Case studies have been performed on IEEE 30-bus system and effectiveness of proposed approach of DSTATCOM placement has been established.

3. PERFORMANCE EVALUATION OF D-STATCOM FOR VOLTAGE FLUCTUATIONS IN POWER DISTRIBUTION SYSTEM

From this Paper we refer-

As demand of quality and reliability of electric power is continuously increasing, Power Quality has now become an important aspect in the current power scenario. Power quality determines quality and ability of electric power available



International Journal of Advanced Research in Electrical, Electronics and Instrumentation Engineering

(An ISO 3297: 2007 Certified Organization)

Website: www.ijareeie.com

Vol. 6, Issue 2, February 2017

at the consumer end. Maintaining voltage, frequency and phase to desired level allows electrical systems to provide quality and reliability of power without considerable loss of performance or life. poor power quality can be caused due to failure of loads and sudden switching of heavy electrical loads in the network, which mainly result in voltage sag and swell , disturbances in loads may also results in voltage fluctuation. However voltage flicker and interruptions are the most common problem which effects power quality.

4. MITIGATION OF VOLTAGE SAG AND VOLTAGE SWELL BY USING D-STATCOM AND PWM SWITCHED AUTOTRANSFORMER

From this Paper we refer-

This paper proposes a novel distribution-level voltage control scheme that can compensate voltage Sag and Swell conditions in three-phase power systems. Faults occurring in power distribution systems or facilities in plants generally cause the voltage sag or swell. Sensitivity to voltage sags and swells varies within different applications. For sensitive loads, even the slightest voltage sag for short duration can cause serious problems. Normally, a voltage interruption trigger protection device, which causes shut down the entire load. In order to mitigate power interruptions, this paper proposes a voltage sag support based on a pulse width modulated autotransformer and D-STATCOM. The proposed devices quickly recognize the voltage sag and voltage swell conditions and correct the voltage by either boosting the input voltage during voltage sag events or reducing the voltage during swell events. Simulation analysis of these devices is performed in PSCAD/EMTDC and performance analysis of the system is presented for various levels of sag and swell. Simulation results are presented for various conditions of sag and swell disturbances in the supply voltage to show the compensation effectiveness.

5. COMPARATIVE STUDY ON VOLTAGE SAG/SWELL MITIGATION BY MODELLING AND SIMULATION OF DVR AND DSTATCOM

From this Paper we refer-

The electrical energy is one of the easily used forms of energy. It can be easily converted to other forms of energy. With the advancement of technology, the dependency on the electrical energy has been increased greatly. Computer and telecommunication networks, railway network banking, post office, life support system are few application that just cannot function without electricity. At the same time these applications demand qualitative energy. However, the quality of power supplied is affected by various internal and external factors of the power system. The presence of harmonics, voltage and frequency variations deteriorate the performance of the system. In this paper the frequently occurring power quality problem- voltage variation is discussed. The voltage sag/dip is the most frequently occurring problem. There are many methods to overcome this problem. Among them the use of FACT devices is an efficient one. This paper presents an overview of the FACT devices like- DVR, D-STATCOM, in mitigating voltage sag. Each one of the above device is studied and analyzed. And also the control strategies to control these devices are presented in this project. The proposed control strategies are simulated in MATLABSIMULINK environment and the results are presented in this paper. A comparative study based on the performance of these devices in mitigating voltage sag is also presented.

6. DESIGN AND SIMULATION STUDIES OF D-STATCOM FOR VOLTAGE SAG, SWELL MITIGATION

From this Paper we refer-

This paper presents the design of a prototype distribution static compensator (D-STATCOM) for voltage sag mitigation in an unbalanced distribution system. The D-STATCOM is intended to replace the widely used static Varcompensator (SVC). The model is based on the Voltage Source Converter (VSC) principle. A new PWM based control scheme has been implemented to control the electronic valves in two level of VSC. The D-STATCOM injects a current into the system to mitigate the voltage sags. In this work, the 6-pulse D-STATCOM configuration with IGBT has been designed using MATLAB SIMULINK. Accordingly, simulations are first carried out to illustrate the use of D-STATCOM in mitigating voltage sag in a distribution system. Simulation results prove that the D-STATCOM is capable of mitigating voltage sag as well as improving power quality of a system.



International Journal of Advanced Research in Electrical, Electronics and Instrumentation Engineering

(An ISO 3297: 2007 Certified Organization)

Website: www.ijareeie.com

Vol. 6, Issue 2, February 2017

7. NEURAL NETWORK CONTROLLER BASED DSTATCOM FOR VOLTAGE SAG MITIGATION AND POWE QUALITY ISSUE

From this Paper we refer-

In this paper review and describe one of the most important electric power systems problems, it's a voltage sag. When this phenomenon occurs, the impact on devices and equipment used in all types of domestic, commercial and industrial loads, which leads to malfunction, many of which will be a serious and very significant effects, particularly in industrialized loads being represent the backbone of life. This made as a major part of electric power quality provides the consumers. Power quality is one of the most important areas of generation, transmission and distribution systems of the power system. In this paper, design model of the electric power system which has been generating a voltage sag phenomenon has also been the study and analysis of the reasons for it.

8. MITIGATION TECHNIQUE FOR VOLTAGE SAG & SWELL BY USING DYNAMIC VOLTAGE RESTORER

From this Paper we refer-

This paper presents the application of dynamic voltage restorers (DVR) on power distribution Systems for mitigation of voltage sags/swells at critical loads. DVR is one of the compensating types of custom power devices. An adequate modeling and simulation of DVR, including controls in MATLAB, show the flexibility and easiness of the MATLAB environment in studying and Understanding such compensating devices. Simulation results are presented to illustrate and understand the performances of DVR in supporting load voltages under voltage sags/swells conditions

IV. DISTRIBUTION STATIC COMPENSATOR (STATCOM)

A D-STATCOM consists of a two-level VSC, a dc energy storage device, controller and a coupling transformer connected in shunt to the distribution network. STATCOM is often used in transmission system. When it is used in distribution system, it is called DSTATCOM (STATCOM in Distribution system). DSTATCOM is a key FACTS controller and it utilizes power electronics to solve many power quality problems commonly faced by distribution systems. Potential applications of D-STATCOM include power factor correction, voltage regulation, load balancing and harmonic reduction. Comparing with the SVC, the D-STATCOM has quicker response time and compact structure. It is expected that the D-STATCOM will replace the roles of SVC in nearly future D-STATCOM and STATCOM are different in both structure and function, while the choice of control strategy is related to the main-circuit structure and main function of compensators, so D-STATCOM and STATCOM adopt different control strategy. At present, the use of STATCOM is wide and its strategy is mature, while the introduction of D-STATCOM is seldom reported. Refer to the strategies for STATCOM, in this paper, a compound control strategy used in D-STATCOM is presented to achieve the purpose of rapid-response compensation. A PWM-based control scheme has been implemented to control the electronic valves in the two-level VSC used in the D-STATCOM. Reactive power compensation is an important issue in the control of distribution systems. Reactive current increases the distribution system losses, reduces the system power factor, shrink the active power capability and can cause large-amplitude variations in the load-side voltage. Various methods have been applied to mitigate voltage sags. The conventional methods use capacitor banks, new parallel feeders, and uninterruptible power supplies (UPS). However, the power quality problems are not completely solved due to uncontrollable reactive power compensation and high costs of new feeders and UPS. The D-STATCOM has emerged as a promising device to provide not only for voltage sag mitigation but also for a host of other power quality solutions such as voltage stabilization, flicker suppression, power factor correction, and harmonic control. D-STATCOM is a shunt device that generates a balanced three-phase voltage or current with ability to control the magnitude and the phase angle. Generally, the D-STATCOM configuration consists of a typical 12-pulse inverter arrangement, a dc energy storage device; a coupling transformer connected in shunt with ac system, and associated control circuits. The configurations that are more sophisticated use multi-pulse and/or multilevel configurations. The VSC converts the dc voltage across the storage device into a set of three-phase ac output voltages. These voltages are in phase and coupled with the ac system of network through the reactance of the coupling transformer. A control method based on RMS voltage measurement has been presented in and where they have been presented a PWM-based control

scheme that requires RMS voltage measurements and no reactive power measurements are required. In addition, in this given method, Clark and Park transformations are not required. However, they have been investigated voltage sag/swell mitigation due to just load variation while no balanced and unbalanced faults have been investigated. A new control method for mitigating the load voltage sags caused by all types of fault is proposed. A Lookup Table is used to detect the proportional gain of PI controller, which is based only on Trial and Error. While in this paper, the proportional gain of the PI controller is fixed at a same value, for all types of faults, by tuning the transformer reactance in a suitable amount. Then the robustness and reliability of the proposed method is more than the mentioned methods. In this method, the dc side topology of the D-STATCOM is modified for mitigating voltage distortions and the effects of system faults on the sensitive loads are investigated and the control of voltage sags are analyzed and simulated.

V. CONTROL STRATEGY

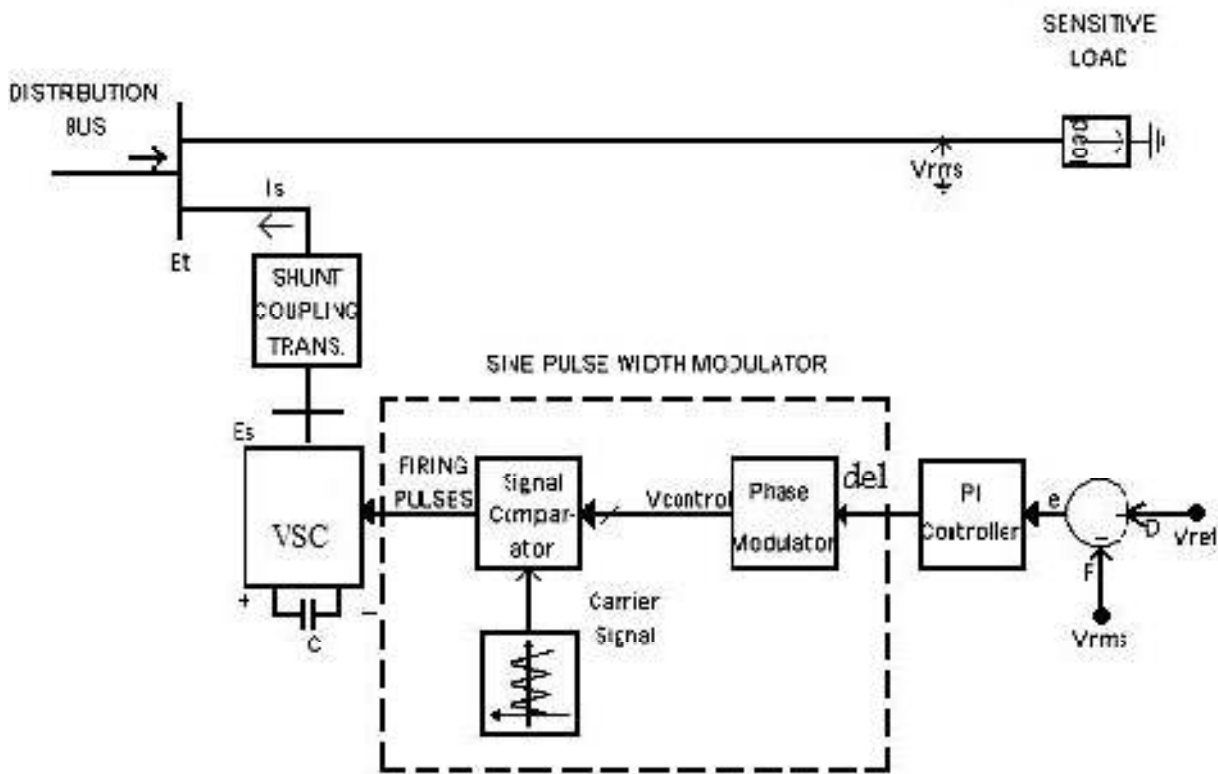

Fig 1. Control scheme designed for the D-STATCOM

The block diagram of the control scheme designed for the DSTATCOM is shown in Fig. 1. It is based only on measurements of the voltage V_{RMS} at the load point. The voltage error signal is obtained by comparing the measured V_{RMS} voltage with a reference voltage, V_{RMS_Ref} . A PI controller processes the difference between these two signals in order to obtain the phase angle δ that is required to drive the error to zero.

VI. SIMULATION MODEL FOR THE SYSTEM

To enhance the performance of distribution system, D-STATCOM is connected to the distribution system. D-STATCOM is designed using MATLAB simulink. The figure 2 comprises a 230kV, 50Hz transmission system, feeding into the primary side of a 3-winding transformer connected, 230/11/11kv. A varying load is connected to the

International Journal of Advanced Research in Electrical, Electronics and Instrumentation Engineering

(An ISO 3297: 2007 Certified Organization)

Website: www.ijareeie.com

Vol. 6, Issue 2, February 2017

11kV, secondary side of the transformer. The capacitor on the dc side provides the DSTATCOM energy storage capabilities. Circuit breaker is used to control the period of operation of the DSTATCOM.

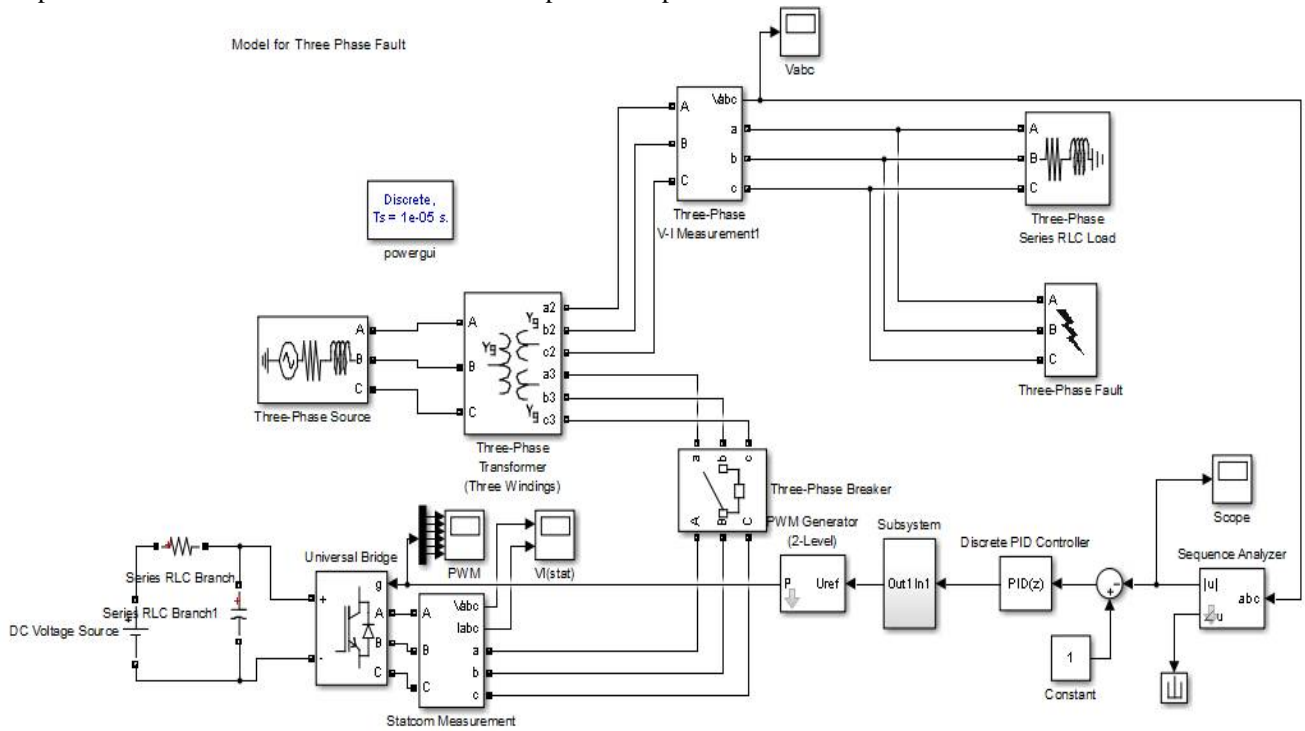

Fig 2 simulation model for three phase fault

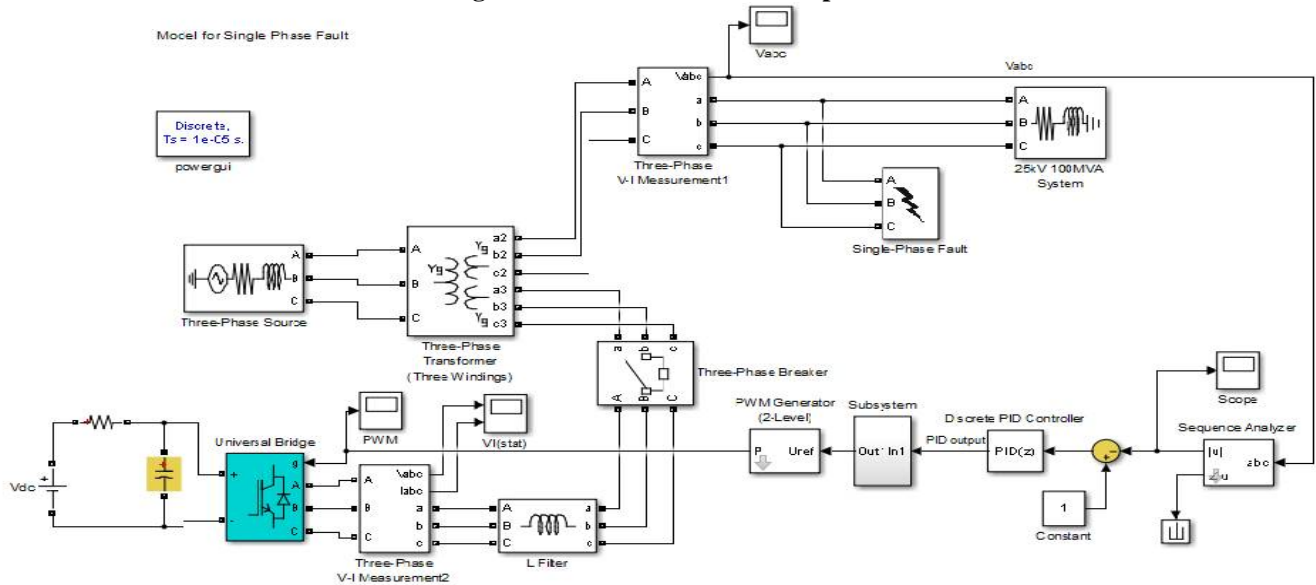

Fig. 3 simulation model for the single phase fault

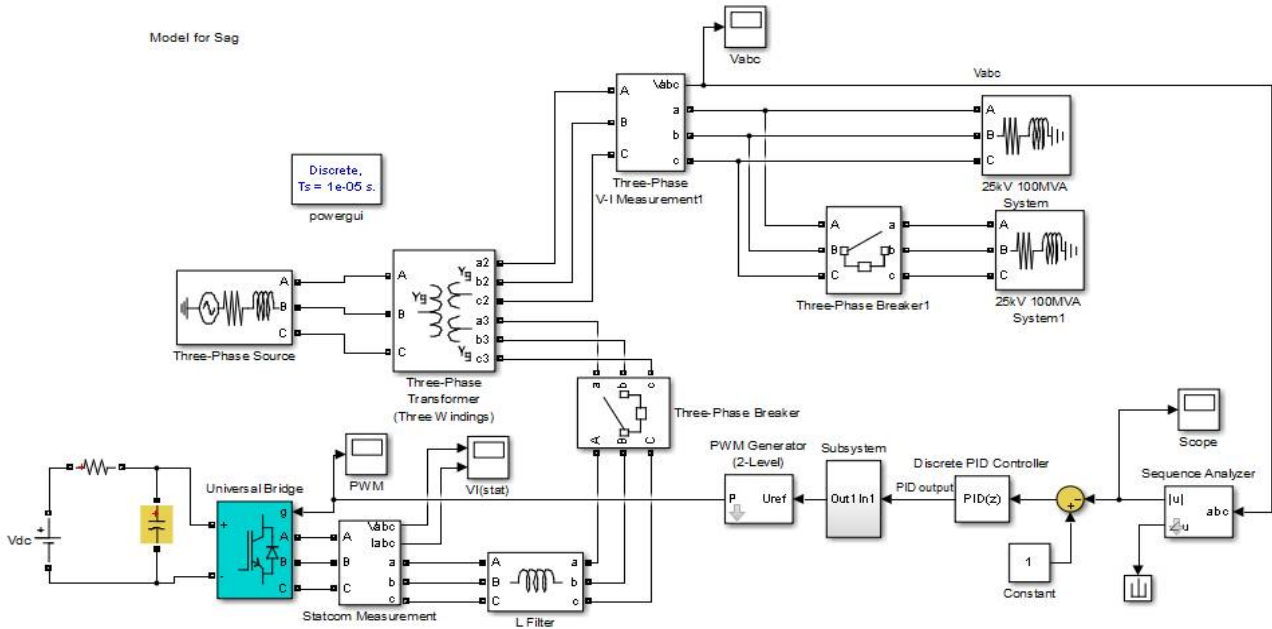

Fig. 4 simulation model for sag

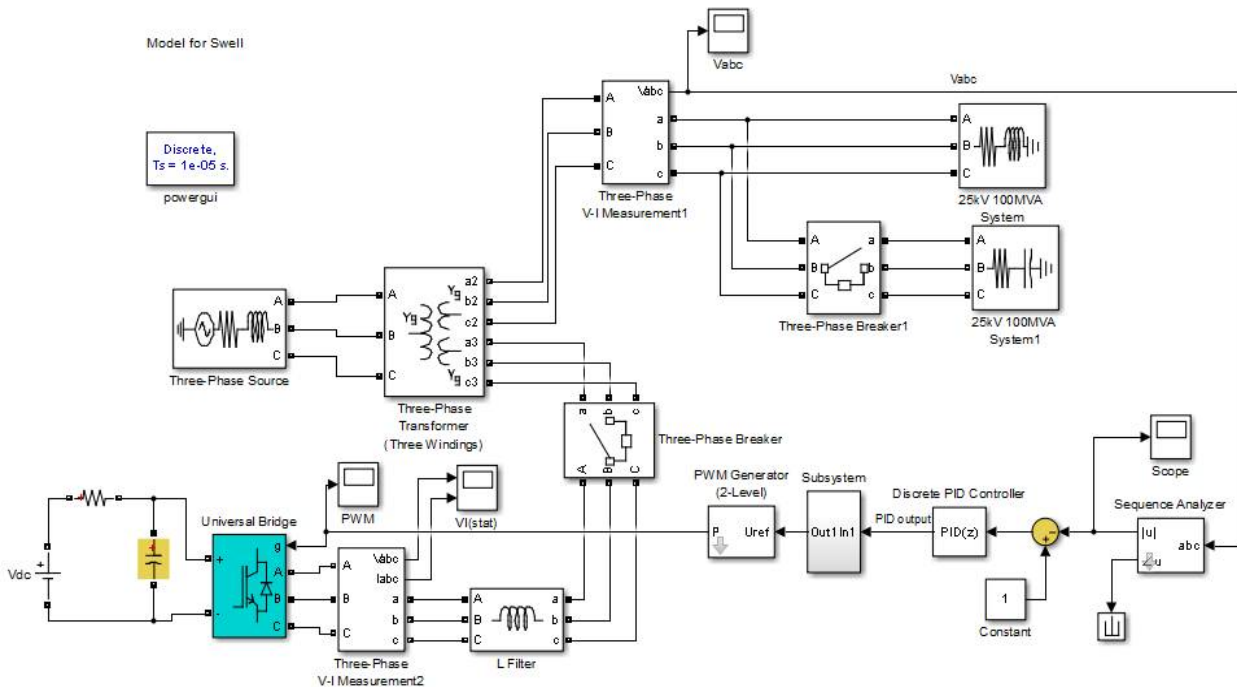

Fig. 5 simulation model for swell

The aim of the control scheme is to maintain constant magnitude of voltage at the point where a sensitive load is connected, under system disturbances. No reactive power measurements are required; control system only measures the rms voltage at the load point. The switching strategy of VSC is based on a sinusoidal PWM technique which offers simplicity and good response. Modern semiconducting switches such as MOSFETs or IGBTs are suitable components for high efficiency controllers. High switching frequencies can be used to improve on the efficiency of the converter,

without incurring significant switching losses in inverter. The input of controller is typically an error signal, which is the difference between reference signal and actual system output signal. The controller input is an error signal obtained from the reference voltage and measured rms voltage of terminal. Such a error is processed by a PI controller and the output is the angle δ , which is provided to the PWM generator. The error signal is generated by comparing the reference value and the actual value. . Proportional-integral controller (PI Controller) is a feedback loop controller which drives the system to be controlled with the weighted sum of the error signal and the integral of that value. In this case, PI controller will process the error signal to zero that means the load rms voltage is brought back to the reference voltage by comparing the reference voltage with the measured rms voltages.

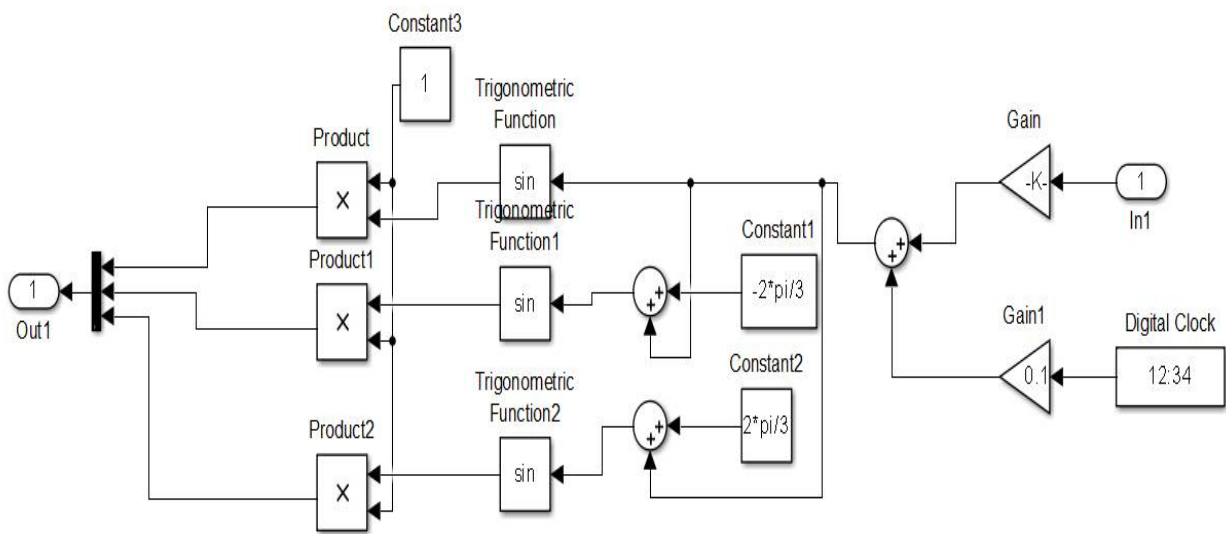

Fig 6 phase modulation of the control angle δ

VII. SIMULATION RESULT FOR THE SYSTEM

Simulation result for load (3 phase balanced sag) In this system balanced sag is occur for a duration 500ms to 900ms.

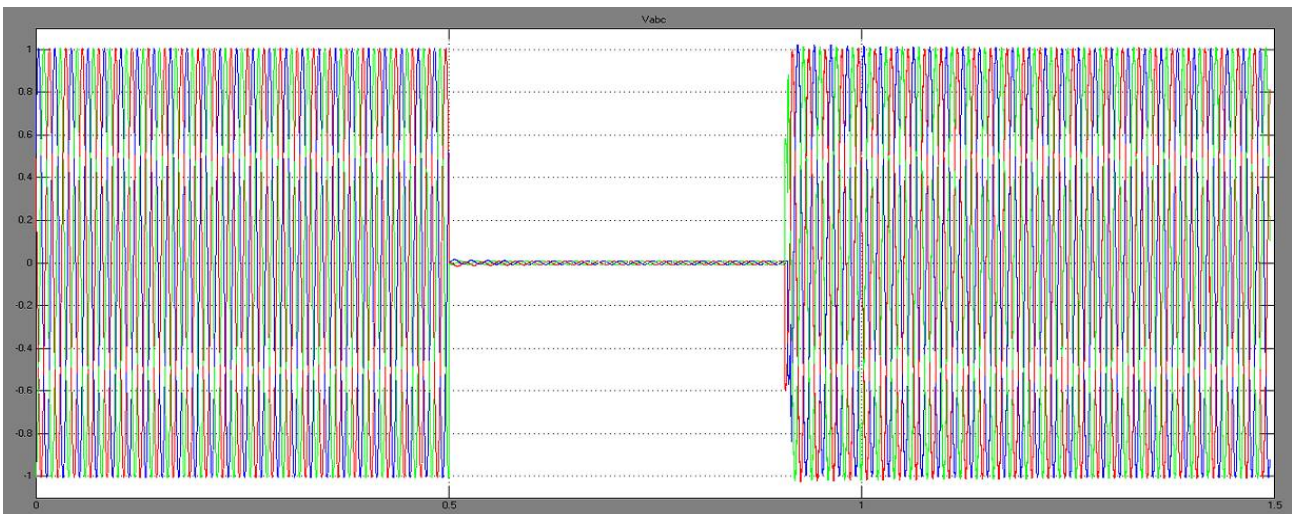

Fig.7.



International Journal of Advanced Research in Electrical, Electronics and Instrumentation Engineering

(An ISO 3297: 2007 Certified Organization)

Website: www.ijareeie.com

Vol. 6, Issue 2, February 2017

Simulation results of Vrms at load point:

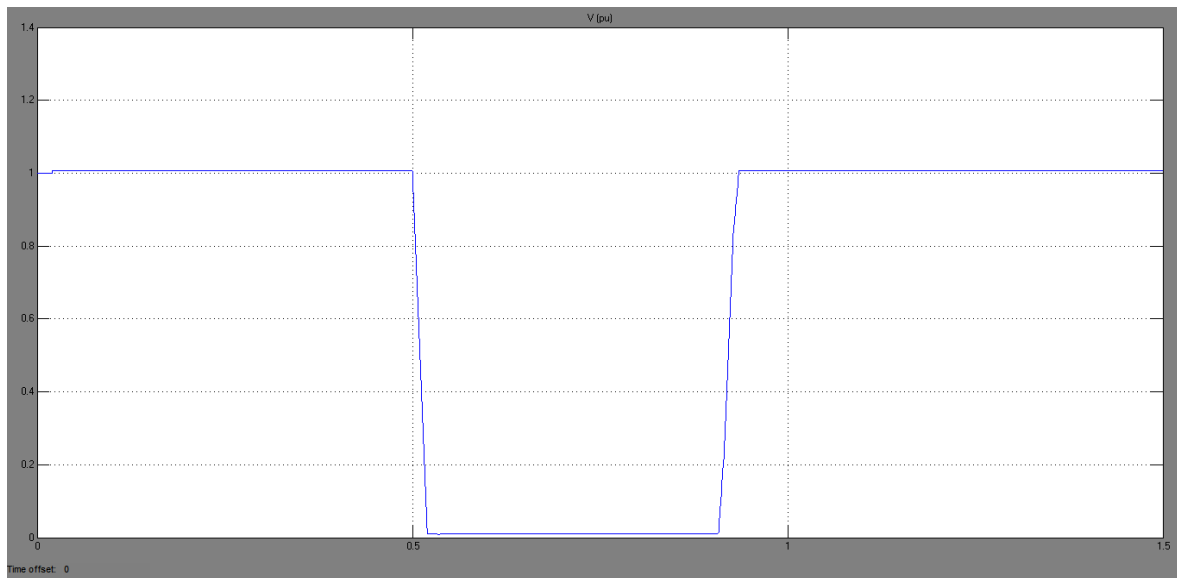

Fig.8

Simulation results after compensation at load side

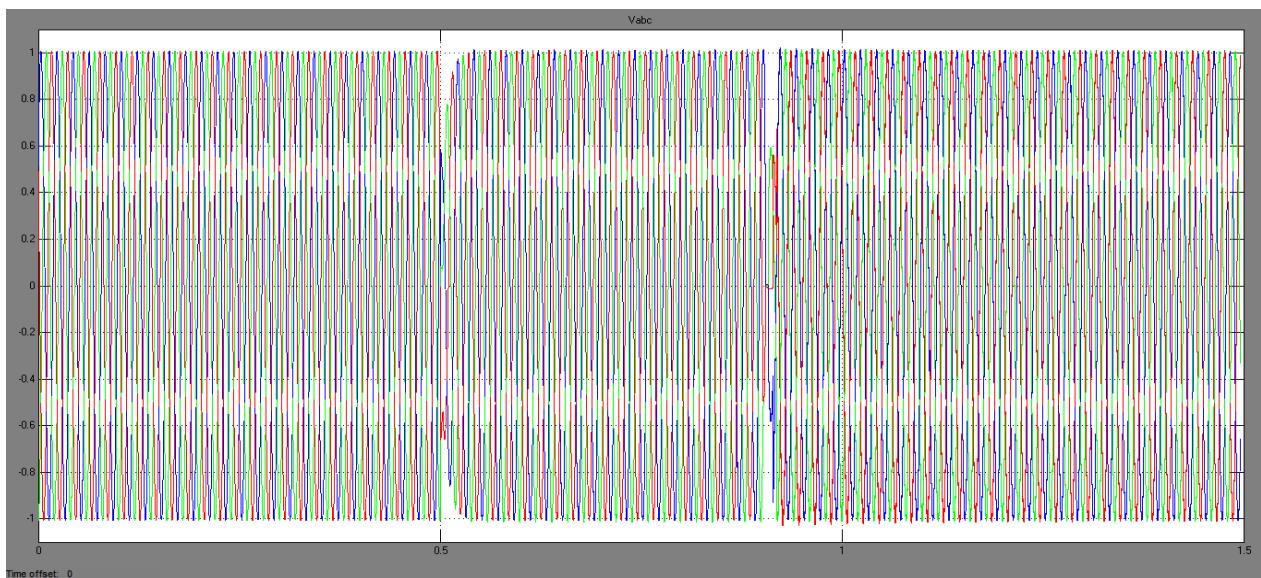

Fig.9



International Journal of Advanced Research in Electrical, Electronics and Instrumentation Engineering

(An ISO 3297: 2007 Certified Organization)

Website: www.ijareeie.com

Vol. 6, Issue 2, February 2017

Simulation results of Vrms after compensation at load point:

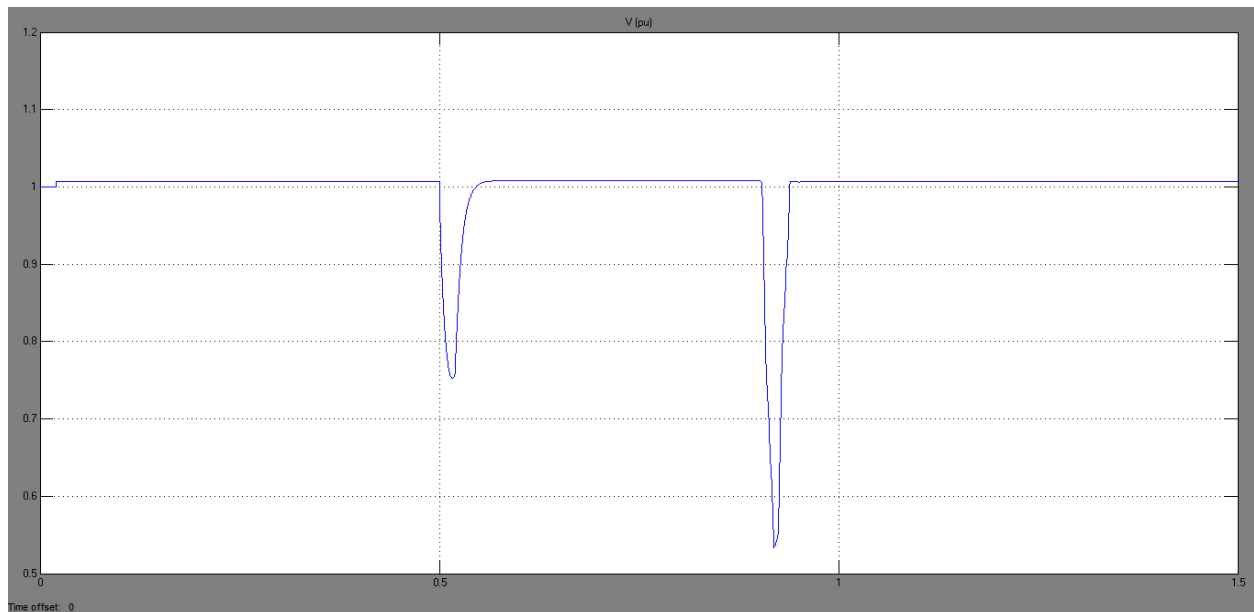

Fig.10

Simulation results of Voltage swell

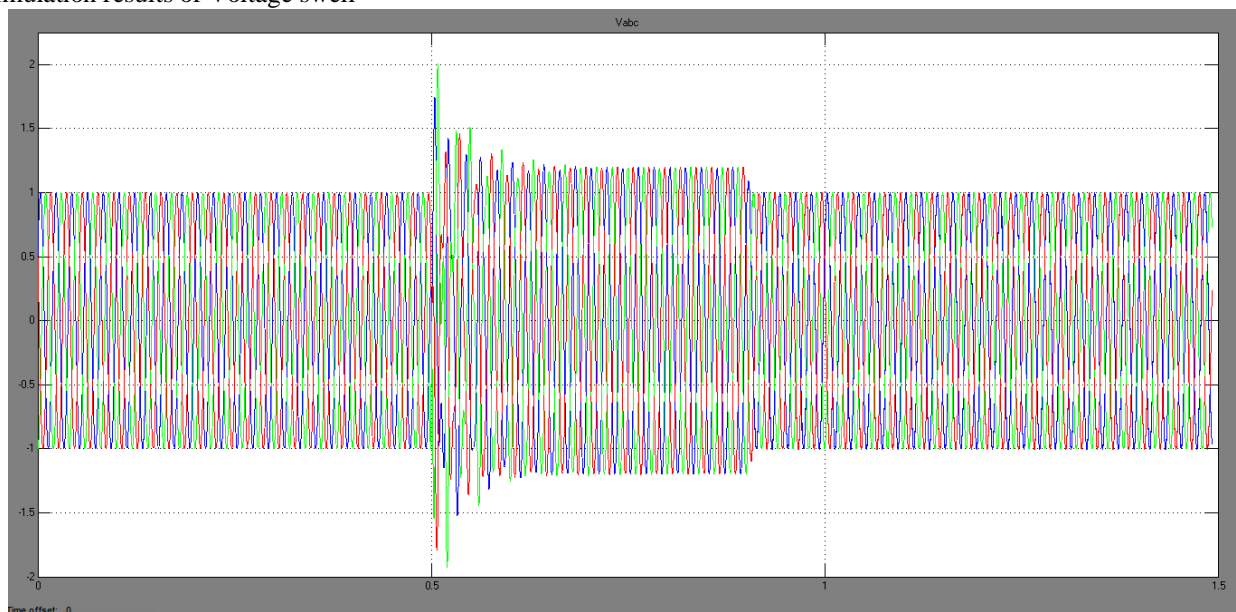

Fig.11



International Journal of Advanced Research in Electrical, Electronics and Instrumentation Engineering

(An ISO 3297: 2007 Certified Organization)

Website: www.ijareeie.com

Vol. 6, Issue 2, February 2017

Simulation result of Voltage Vrms at load point without D-STATCOM

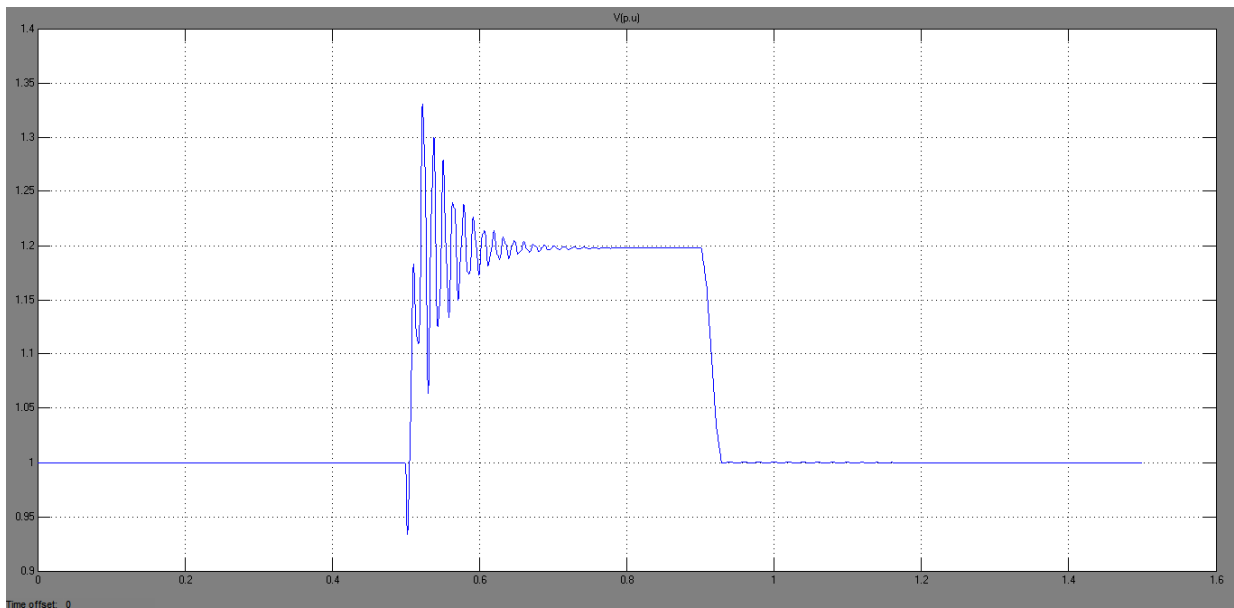

Fig.12

Simulation result of after compensation at load point

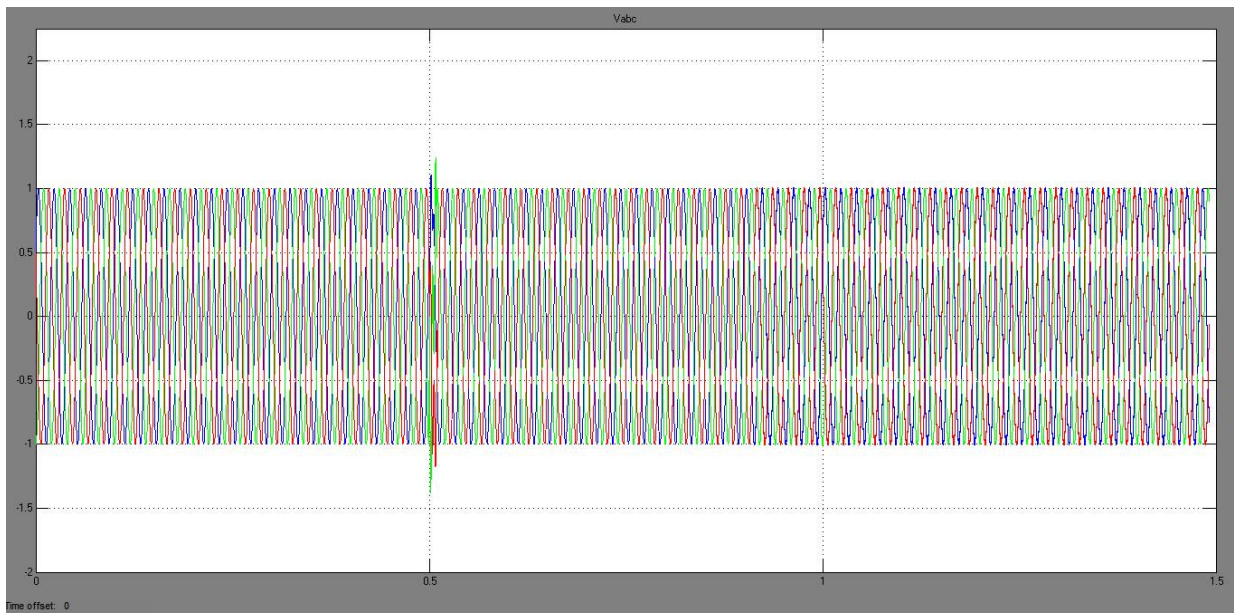

Fig.13

Simulation result of Voltage Vrms at load point with D-STATCOM

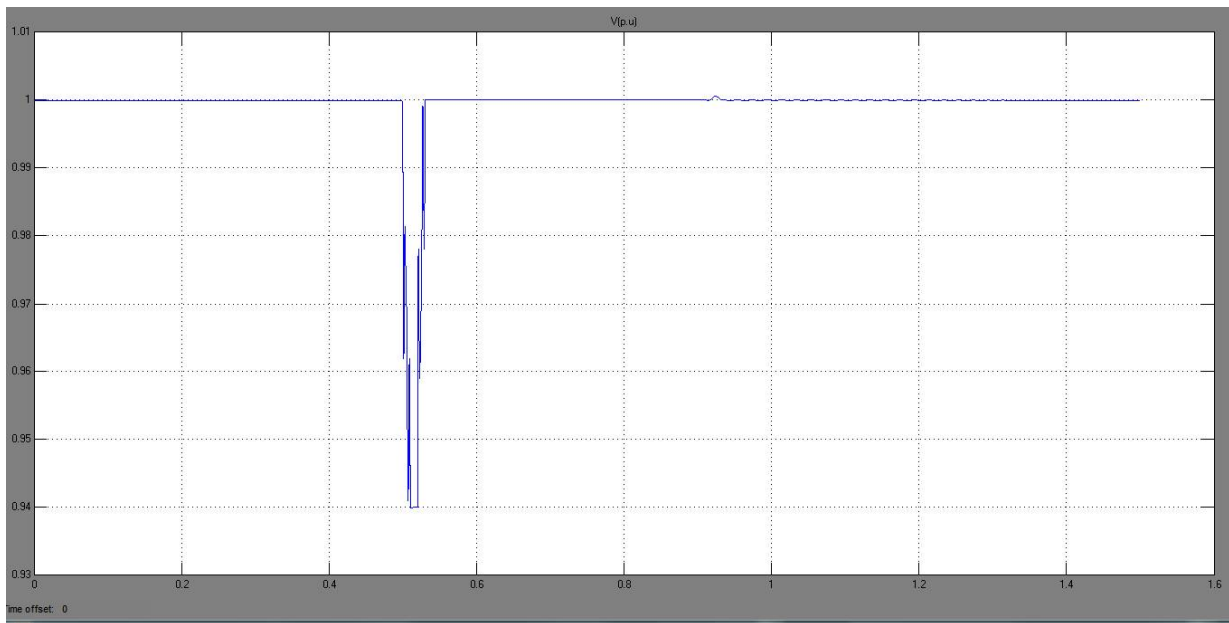

Fig.14

Under normal conditions D-STATCOM continuously monitors the load voltage and generates the error voltage. The voltage sag can be created by using either load switching or by using three phase fault. The load voltage corresponding to sag is shown in Fig 7.1. The d-statcom can mitigate the sag as shown in Fig 7.3.

Voltage swell created by using a capacitor bank switching during a period of 0.5s to 0.9s. Under this condition voltage swell is experienced. By using D-statcom it can be eliminated. The corresponding wave forms are shown in Figs 7.5 and Fig 7.6.

VIII. HARDWARE FABRICATION, TESTING AND RESULTS

In today's scenario, it is very essential to design appropriate compensator in the power system to improve the power quality. This is due to increase in a wide variety of digital loads that pollute the power system. Improper design of compensators results in either in its over-capacity or under-capacity. Over-capacity of the compensator increases the cost of the system while under capacity of the compensators leads to an interruption in the operation of the system. It is necessary to design an appropriate controller to provide uninterrupted operation at a lower cost by proper selecting the control system components.

International Journal of Advanced Research in Electrical, Electronics and Instrumentation Engineering

(An ISO 3297: 2007 Certified Organization)

Website: www.ijareeie.com

Vol. 6, Issue 2, February 2017

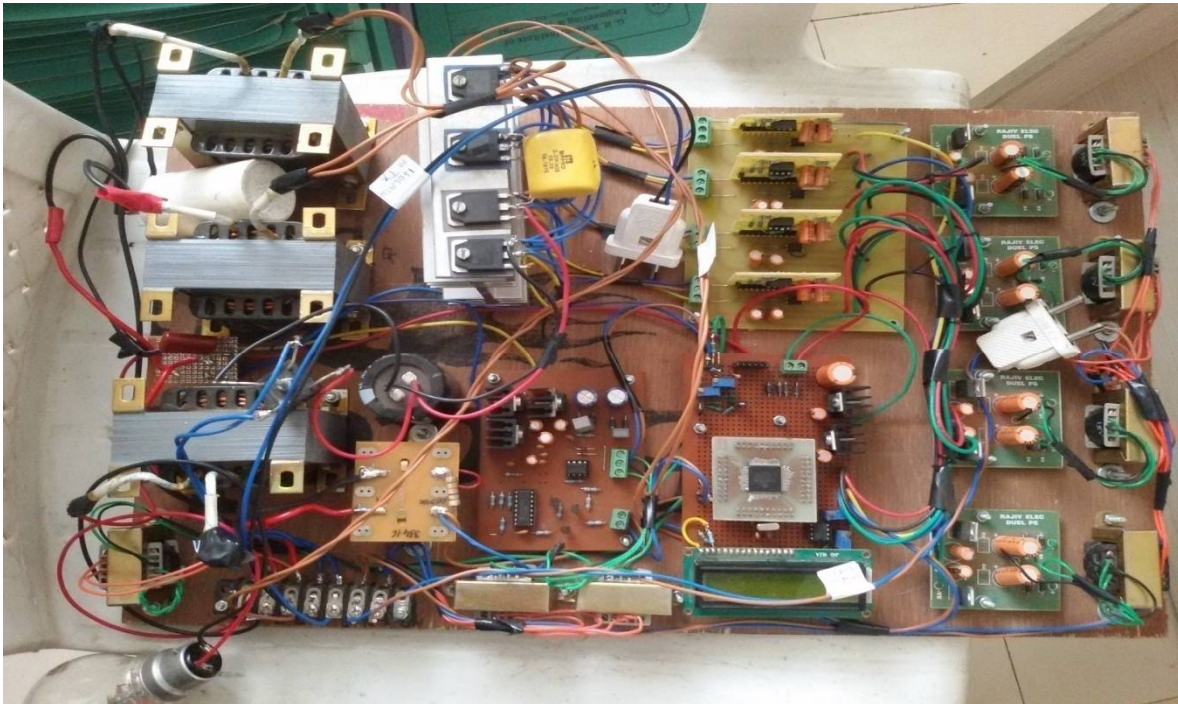

A. RESULT TABLE

Sr no.	V _{in}	V _{out}	V _{comp}
1	90<120<150	120	30%

IX. CONCLUSION & FUTURE SCOPE

The performance of a DSTATCOM in mitigating voltage sag/ swell is demonstrated with the help of MATLAB. The modeling and simulation results of a DSTATCOM are presented. D-STATCOM is promising device which is used for voltage sag,swell mitigation at distribution side. In this work only the V_{rms} value is required to measure.DSTATCOM compensator is a flexible device which can operate in currentcontrol mode for compensating voltage variation, unbalance and reactive power and in voltage control mode as a voltage stabilizer. The latter feature enables its application for compensation of dips coming from the supplying network.In addition, the regulated VRMS voltage showed a reasonably smooth profile. It was observed that the load voltage is very close to the reference value, i.e., 1pu and the voltage sags are completely minimized. The hardware results showed clearly the performance of the Dstatcom in mitigating voltage sag as well as swell. This thesis explained the two level VSC based DSTATCOM and can be extended to multilevel inverter based DSTATCOM to reduce the harmonic content in current. The DSTATCOM can be designed using a current source inverter. An integrated DSTATCOM controller can be design for voltage regulation, reactive power compensation, power factor improvement and unbalanced load compensation.

REFERENCES

- [1] D.R.Patil&Komal K Madhale, "Design And Simulation Studies of Voltage Sag, Swell Mitigation" IRNet Transaction on Electrical and Electronics Engineering.
- [2] Amin Nazarloo, Student Member, IEEE, SeyedHosseinHosseini, Member, IEEE, EbrahimBabaei, Member,IEEE, "Flexible DSTATCOM Performance as a Flexible Distributed Generation in Mitigating Faults" 2011 2nd Power Electronics, Drive Systems and Technologies Conference.
- [3] N.SrinivasaRao&H.J.Jayatheertha, "Modeling and Simulation of DSTATCOM for Power Quality Enhancement in Distribution System" International Journal of Engineering Research & Technology, ISSN:2278-0181, Vol.1 Issue 5, July- 2012.
- [4] Simulation of DSTATCOM and DVR in power systems by S.V.Kumar and SIVA NAGARAJU J.N.T.U College of Engineering, Kakinada, A.P, India.
- [5] Dugan, Roger C.; McGranaghan, Mark F.; Beaty, H Wayne. 1996. "Electrical Power Systems Quality". McGraw Hill Companies, Inc.
- [6] Dr.P.S.Bimbhra, "Power Electronics" Khanna Publishers, Fourth Edition 2012.